

UNIT-3

1. Draw the Block Schematic of AF Wave analyzer and explain its principle and Working?

ANS: The wave analyzer consists of a very narrow pass-band filter section which can be tuned to a particular frequency within the audible frequency range (20 Hz to 20 KHz). The block diagram of a wave analyzer is as shown in fig 1.

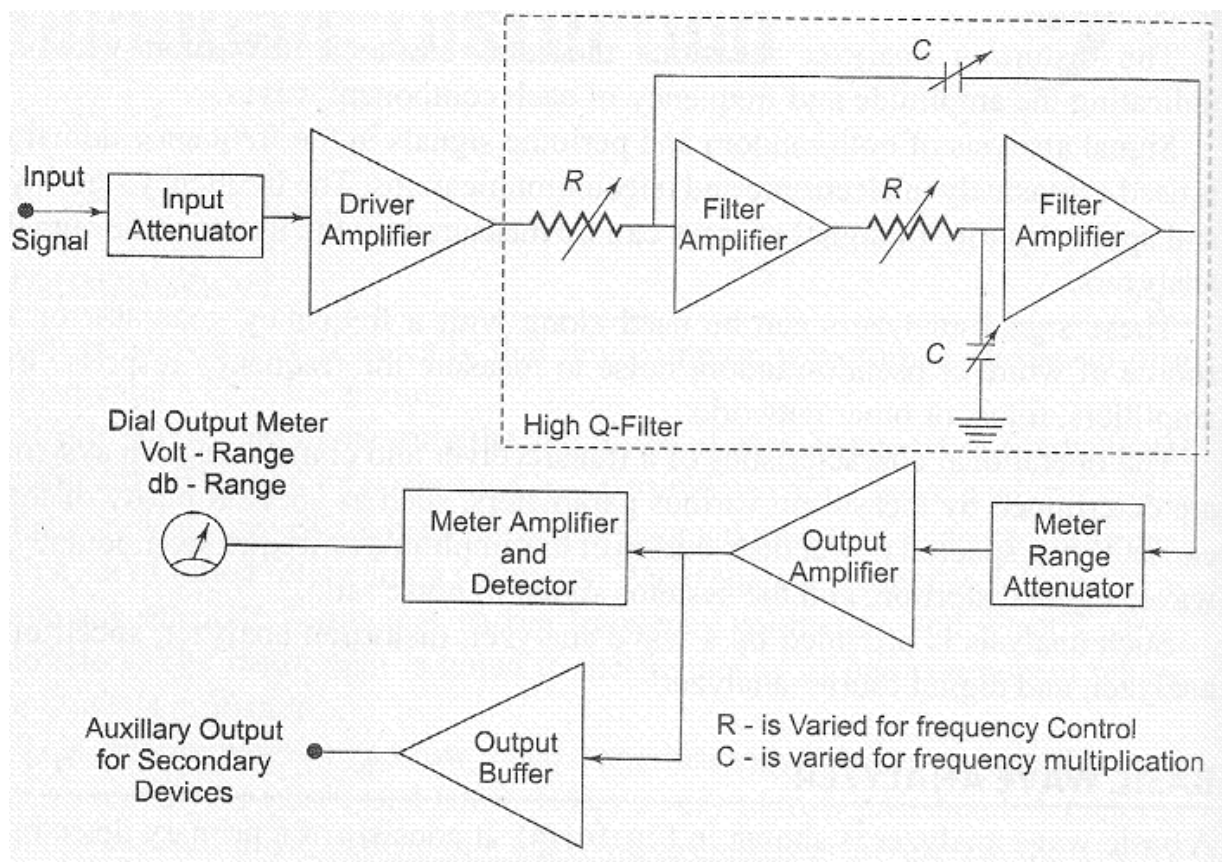

fig 1 Frequency wave analyzer

The complex wave to be analyzed is passed through an adjustable attenuator which serves as a range multiplier and permits a large range of signal amplitudes to be analyzed without loading the amplifier.

The output of the attenuator is then fed to a selective amplifier, which amplifies

the selected frequency. The driver amplifier applies the attenuated input signal to a high-Q active filter. This high-Q filter is a low pass filter which allows the frequency which is selected to pass and reject all others. The magnitude of this selected frequency is indicated by the meter and the filter section identifies the frequency of the component. The filter circuit consists of a cascaded RC resonant circuit and amplifiers. For selecting the frequency range, the capacitors generally used are of the closed tolerance polystyrene type and the resistances used are precision potentiometers. The capacitors are used for range changing and

the potentiometer is used to change the frequency within the selected pass-band, Hence this wave

analyzer is also called a Frequency selective voltmeter. The entire AF range is covered in decade steps by switching capacitors in the RC section

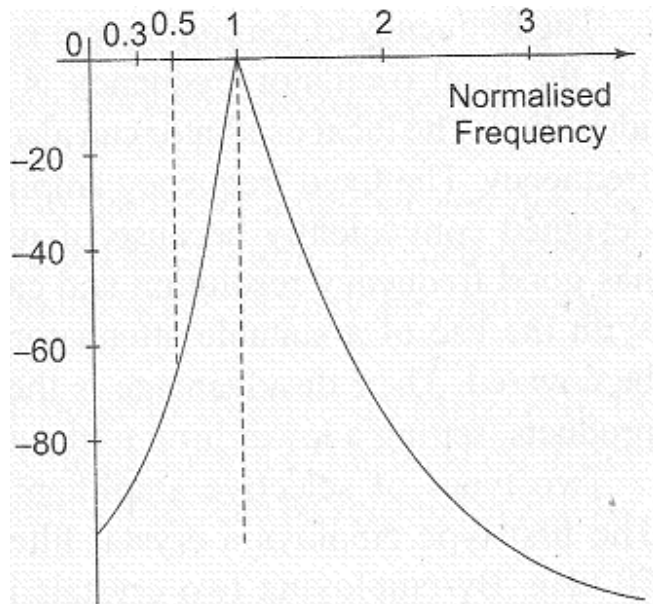

fig 1.2 Relative response in db

The selected signal output from the final amplifier stage is applied to the meter circuit and to an unturned buffer amplifier. The main function of the buffer amplifier is to drive output devices, such as recorders or electronics counters.

The meter has several voltage ranges as well as decibel scales marked on it. It is driven by an average reading rectifier type detector. The wave analyzer must have extremely low input distortion, undetectable by the analyzer itself. The band width of the instrument is very narrow typically about 1% of the selective band given by the following response characteristics shows in fig.1.2

2. What are the applications of wave Analyzer?

Ans: Application of wave analyzer

1. Electrical measurements
2. Sound measurements
3. Vibration measurements.

In industries there are heavy machineries which produce a lot of sound and vibrations, it is very important to determine the amount of sound and vibrations because if it exceeds the permissible

level it would create a number of problems. The source of noise and vibrations is first identified by wave analyzer and then it is reduced by further circuitry.

3. Explain the working of the harmonic distortion analyzer?

Ans:

Fundamental Suppression Type

Distortion analyzer measures the total harmonic power present in the test wave rather than the distortion caused by each component. The simplest method is to suppress the fundamental frequency by means of a high pass filter whose cut off frequency is a little above the fundamental frequency. This high pass allows only the harmonics to pass and the total harmonic distortion can then be measured. Other types of harmonic distortion analyzers based on fundamental suppression are as follows

1. Employing a Resonance Bridge

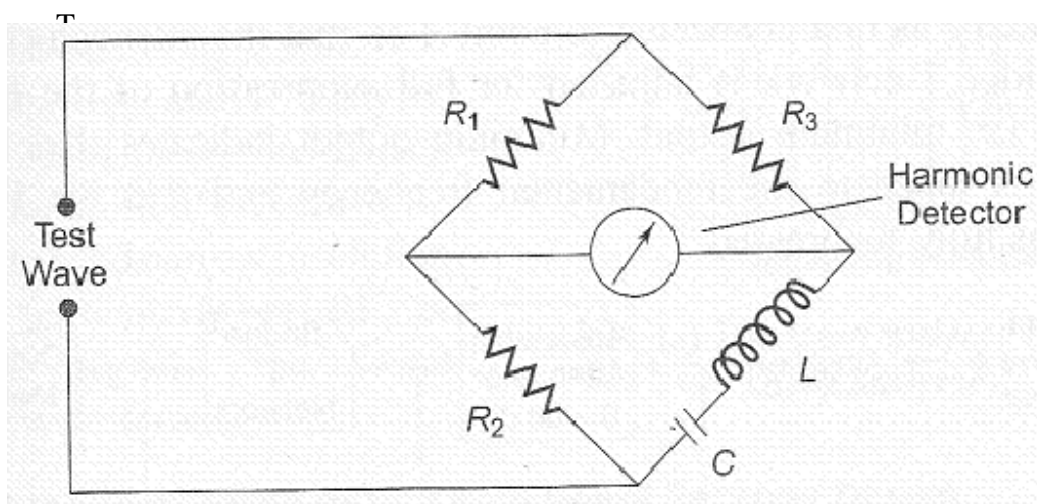

fig 3.1 Resonance Bridge

in fig 3.1 is balanced for the fundamental frequency, i.e. L and C are tuned to the fundamental frequency. The bridge is unbalanced for the harmonics, i.e. only harmonic power will be available at the output terminal and can be measured. If the fundamental frequency is changed, the bridge must be balanced again. If L and C are fixed components, then this method is suitable only when the test wave has a fixed frequency. Indicators can be thermocouples or square law VTVMs. This indicates the rms value of all harmonics. When a continuous adjustment of the fundamental frequency is desired a Wien bridge arrangement is used as shown in fig 3.2.

2. Wien's Bridge Method

The bridge is balanced for the fundamental frequency. The fundamental energy is dissipated in the bridge circuit elements. Only the harmonic components reach the output terminals. The harmonic distortion output can then be measured with a meter. For balance at the fundamental frequency

$$C_1=C_2=C, R_1=R_2=R, R_3=2R_4.$$

3. Bridged T-Network Method

Referring to the fig 3.3 the L and C's are tuned to the fundamental frequency, and R is adjusted to bypass fundamental frequency. The tank circuit being tuned to the fundamental frequency, the fundamental energy will circulate in the tank and is bypassed by the resistance.

Only harmonic components will reach the output terminals and the distorted output can be measured by the meter. The Q of the resonant circuit must be at least 3-5.

One way of using is given in Fig. 3.4 connected to point attenuator is bridge T-network is suppression of the frequency, i.e. indicates that the network is tuned to fundamental and that fundamental is fully suppressed.

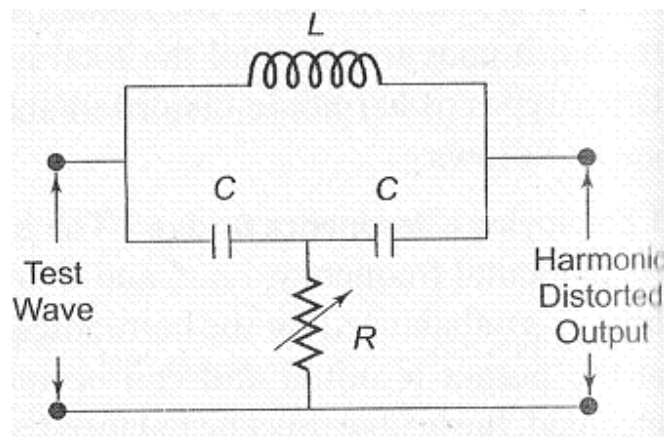

fig 3.3 Bridge T-network method

a bridge T-network
The switch S is first
A so that the
excluded and the
adjusted for full
fundamental
Minimum output
bridged T-
the
frequency
frequencies

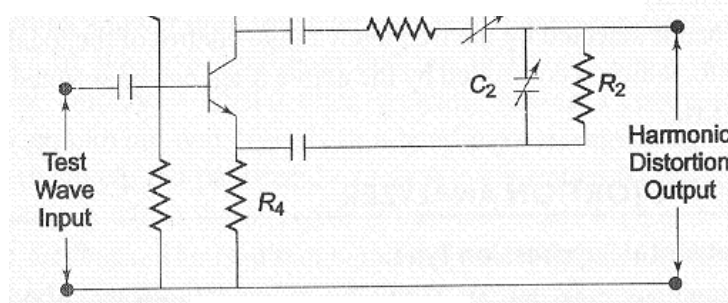

fig 3.2 Wein's bridge method

GRIET/ECE4

The switch is next connected to terminal B, i.e. the bridge T- network is excluded. Attenuation is adjusted until the same reading is obtained on the meter. The attenuator reading indicates the total rms distortion. Distortion measurement can also be obtained by means of a wave analyzer, knowing the amplitude and the frequency of each component, the harmonic distortion can be calculated. However, distortion meters based on fundamental suppression are simpler to design and less expensive than wave analyzers. The advantage is that it gives only the total distortion and not the amplitude of individual distortion components.

4. Draw the block Schematic of a Basic Spectrum Analyzer and explain its working?

Ans: The most common way of observing signals is to display them on an oscilloscope with time as the X-axis (i.e. amplitude of the signal versus time). This is the time domain. It is also useful to display signals in the frequency domain. The providing this frequency domain view is the spectrum analyzer.

A spectrum analyzer provides a calibrated graphical display on its CRT, with frequency on the horizontal axis and amplitude (voltage) on the vertical axis.

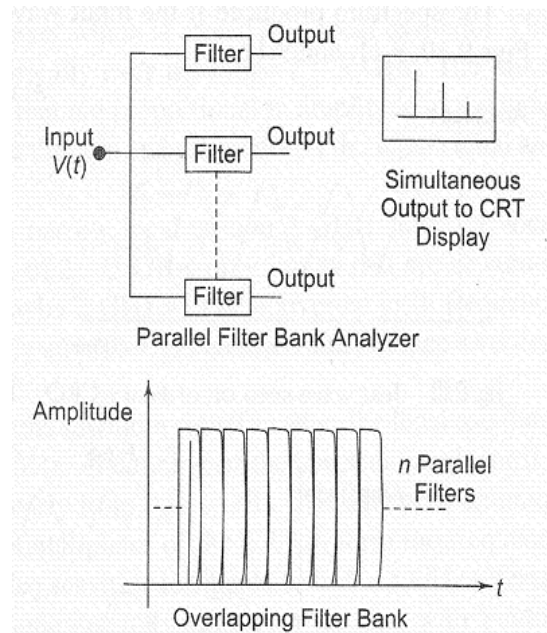

fig 4.1 spectrum analyzer (Parallel filter bank analyzer)

Displayed as vertical lines against these coordinates are sinusoidal components of which the input signal is composed. The height represents the absolute magnitude, and the horizontal location represents the frequency.

These instruments provide a display of the frequency spectrum a given frequency band. Spectrum analyzers use either parallel filter bank or a swept frequency technique.

In a parallel filter in a parallel filter bank analyzer, The frequency range is covered by a series of filters whose central frequencies and bandwidth are so selected that they overlap each others, as shown in fig 4.1.

Typically, an audio analyzer has 32 of these filters, each covering one third of an octave.

For wide band narrow resolution analysis, particularly at RF or microwave signals, the swept Technique is preferred.

Basic Spectrum Analyzer Using Swept Receiver Design

Referring to the block diagram of fig. 4.2, the saw tooth generator provides the saw tooth voltage which drives the horizontal axis element of the scope and this saw tooth voltage is the frequency controlled element of the voltage tuned oscillator. As the oscillator sweeps from f_{\min} to f_{\max} of its frequency band at a linear recurring rate, it beats with the frequency component of the input signal and produce an IF, whenever a frequency component is met during its sweep.

The frequency component and voltage tuned oscillator frequency beats together to produce a difference frequency, i.e. The IF corresponding to the component is amplified and detected if necessary and then applied to the vertical plates of the CRO, producing a display of amplitude versus frequency.

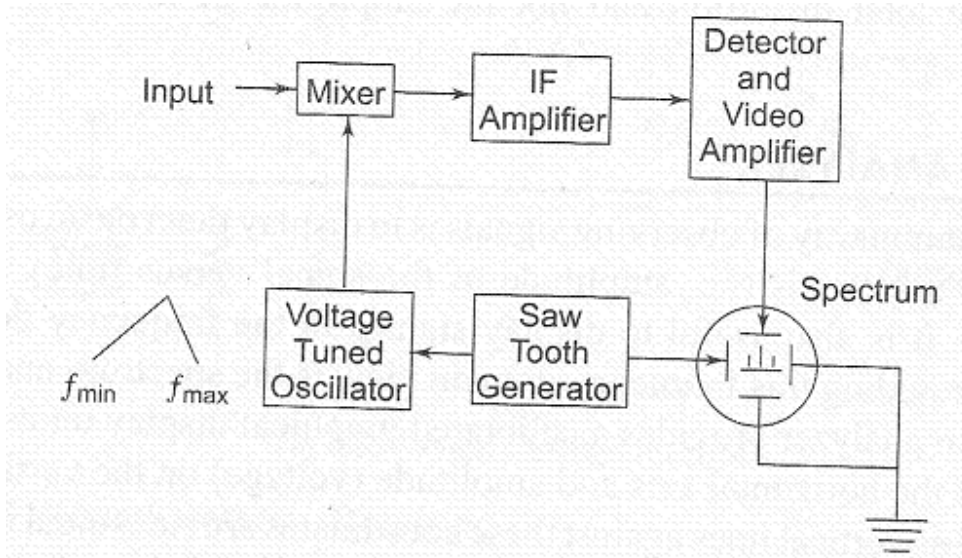

fig 4.2 Spectrum analyzer

The spectrum produced if the input wave is a single toned A.M is given in figs 4.3, 4.4 and 4.5

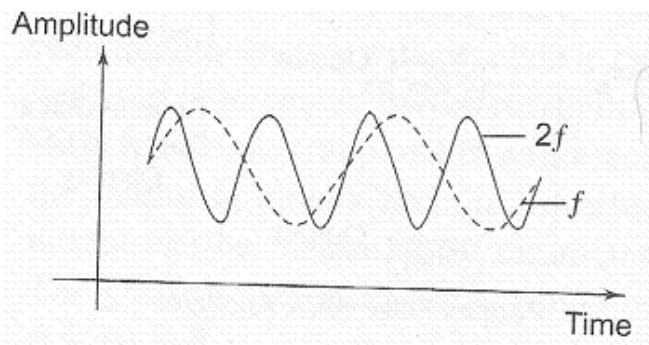

fig 4.3 Test Wave seen on ordinary CRO

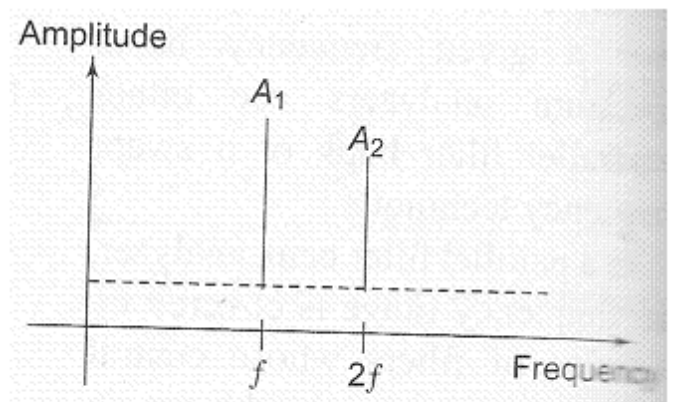

fig4.4 Display on the spectrum CRO

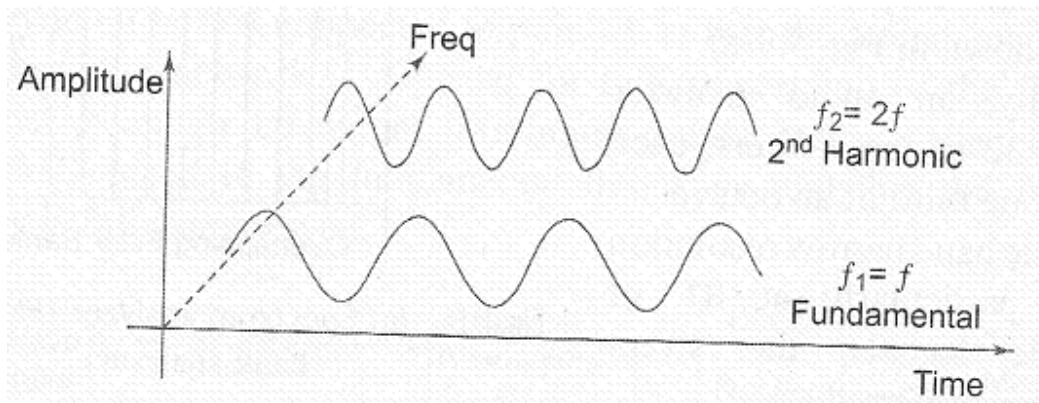

fig 4.5 Test wave form as seen from X-axis(Time) and Z-axis (Frequency)

One of the principal applications of spectrum analyzers has been in the study of the RF spectrum produced in microwave instruments. In a microwave instrument, the horizontal axis can display as wide a range as 2 - 3 GHz for a broad survey and as narrow as 30 kHz, for a highly magnified view of any small portion of the spectrum. Signals at microwave frequency separated by only a few KHz can be seen individually.

The frequency range covered by this instrument is from 1 MHz to 40 GHz, The basic block diagram (Fig. 9.13) is of a spectrum analyzer covering the range 500 kHz to 1 GHz, which is representative of a super heterodyne type.

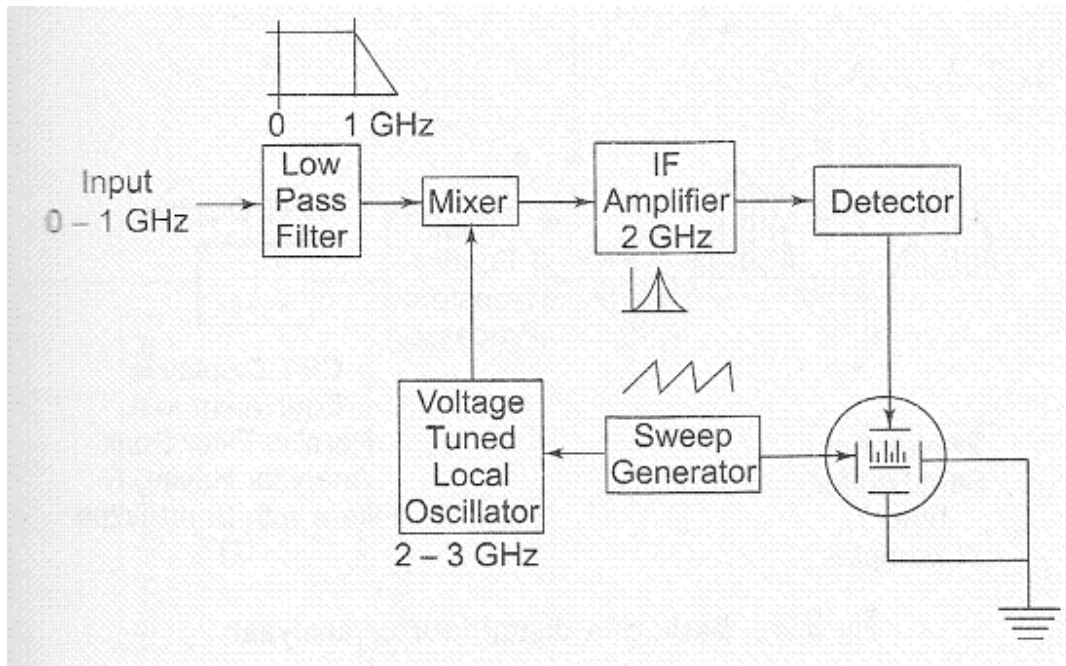

fig 4.6 RF spectrum analyzer

The input signal is fed into a mixer which is driven by a local oscillator. This oscillator is linearly tunable electrically over the range 2 - 3 GHz. The mixer provides two signals at its output that are proportional in amplitude to the input signal but of frequencies which are the sum and difference of the input signal and local oscillator frequency.

The IF amplifier is tuned to a narrow band around 2 GHz since the local oscillator is tuned over the range of 2 - 3 GHz, only inputs that are separated from the local oscillator frequency by 2GHz will be converted to IF frequency band, pass through the IF frequency amplifier, get rectified and produce a vertical deflection on the CRT.

From this, it is observed that as the saw tooth signal sweeps, the local oscillator also sweeps linearly from 2 - 3 GHz. The tuning of the spectrum analyzer is a swept receiver, which sweeps linearly from 0 to 1 GHz. The saw tooth scanning signal is also applied to the horizontal plates of the CRT to form the frequency axis. (The spectrum analyzer is also sensitive to signals from 4 - 5 GHz referred to as the image frequency of the super heterodyne. A low pass filter with a cutoff frequency above 1 GHz at the input suppresses these spurious signals.) Spectrum analyzers are widely used in radars, oceanography, and bio-medical fields

5. With a neat sketch explain the working of a digital Fourier analyzer?

An: A spectrum analyzer, which uses computer algorithm and an analog to digital conversion phenomenon and produces spectrum of a signal applied at its input is known as digital Fourier or digital FFT or digital spectrum analyzer.

Principle

When the analog signal to be analyzed is applied, the A/D converter digitizes the analog signal (i.e., converts the analog signal into digital signal). The digitized signal, which is nothing but the set of digital numbers indicating the amplitude of the analog signal as a function of time is stored in the memory of the digital computer. From the stored digitized data, the spectrum of the signal is computed by means of computer algorithm.

Description:

The block arrangement of a digital Fourier analyzer is illustrated in the figure above fig 5. The analog signal to be analysed is applied to the low pass filter, which passes only low frequency signals and rejects high pass spurious signals. This filter section is used mainly, to prevent aliasing. The output of low pass filter is given to the attenuator. The attenuator is a voltage dividing network whose function is to set the input signal to the level of the A/D converter. The use of attenuator prevents the converter from overloading. The function of A/D converter is to convert the samples of analog data into digital i.e. ., to digitize the analog signal. When the output of A/D converter is applied to the digital computer, the computer analyzes the digitized data and adjusts the attenuator setting accordingly in order to obtain the maximum output from the inverter without any overloading. As soon as the entire analog signal is sampled and digitized by the A/D converter) computer performs calculations on the data according to the programmed algorithm and the calculated spectral components are stored in the memory of the computer.

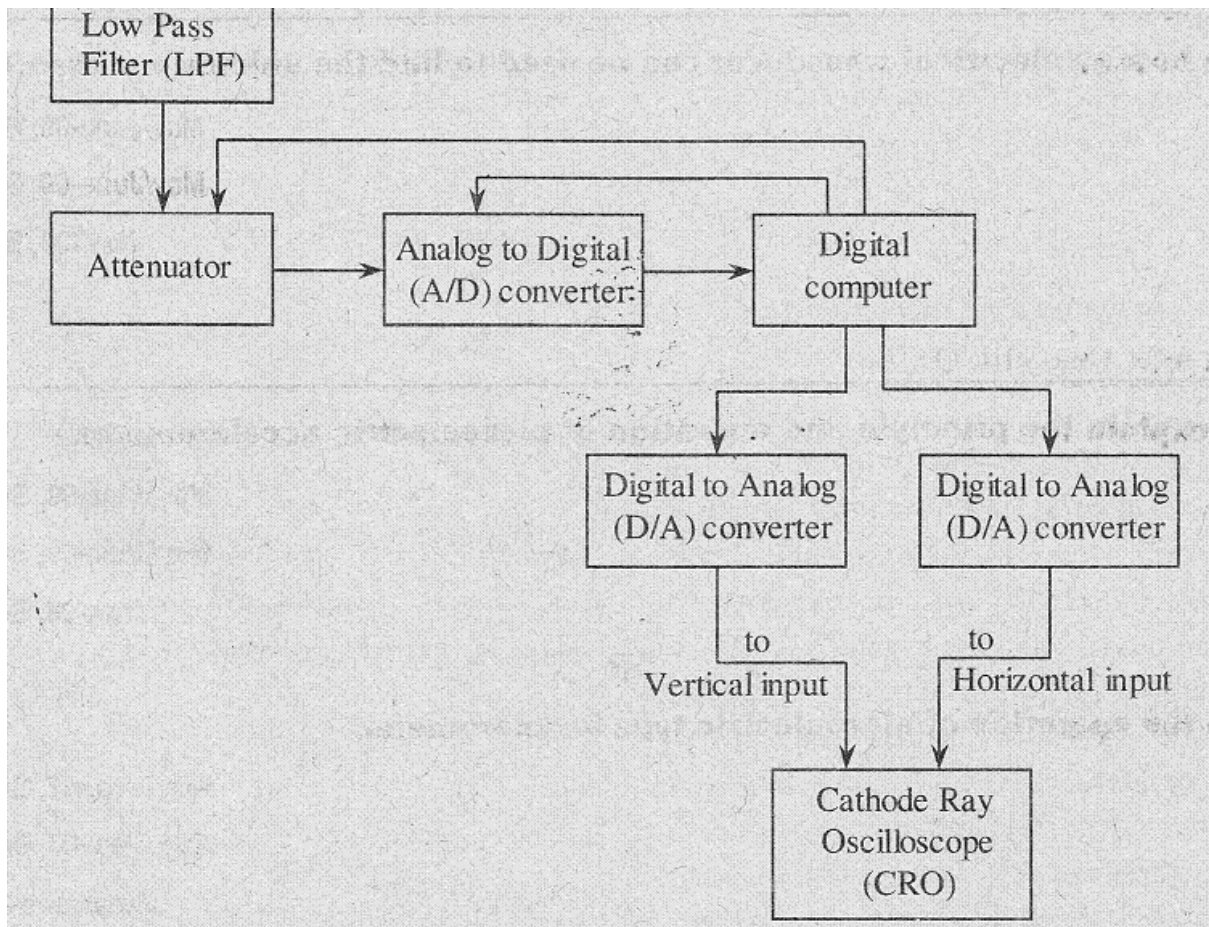

Fig 5 Digital Fourier Analyzer

If the spectral display is to be viewed on the oscilloscope, the digital values of spectral components stored in the computer memory are converted into analog by using D/A converters and then applied to the CRO. Thus the spectral display of the input waveform is obtained on the CRT screen.

Advantages

1. The use of computer avoids most of the hardware circuitry such as electronic switches. Filters and PLLs. The use of less hardware reduces the cost of the analyzer.
2. More mathematical calculations can be carried-out on the spectral display.
3. The rate of sampling analog signal can be modified in order to obtain better spectral display.

6. Differentiate between wave analyzer and harmonic distortion analyzer?

GRIET/ECE11

Ans:

Wave analyzer	Harmonic distortion analyzer
1. These are designed to measure the relative amplitude of each harmonic or fundamental components separately.	1. These are designed to measure the total harmonic content present in a distorted or complex wave form.
2.They indicate the amplitude of single frequency component	2. They do not indicate the amplitude of single frequency component
3.These are tuned to measure amplitude of one frequency component with in a range of 10Hz to 40MHz	3.These can be operated with in a band of 5Hz to 1 MHz frequency
4.These are also known as frequency selective voltmeters, selective level voltmeters, carrier frequency voltmeters	4.It is general know as distortion analyzer
5. These are used with a set of tuned filters and a voltmeter.	5. These can be used along with a frequency generator.
6. Wave analyzers provide very high frequency resolution.	6. They measure quantitative harmonic distortions very accurately.7.
7.These can be used for electrical measurements, sound ,vibration ,noise measurement in industries	7.These can be used to measure frequency stability and spectral purity of signal sources

7. Explain the two types of spectrum analyzers?**Ans:**

The two types of spectral analyzers are,

1. Fliter Bank Spectrum analyzer.
2. Super hetero dyne Spectrum analyzer.

1. Filter Bank Spectrum analyzer

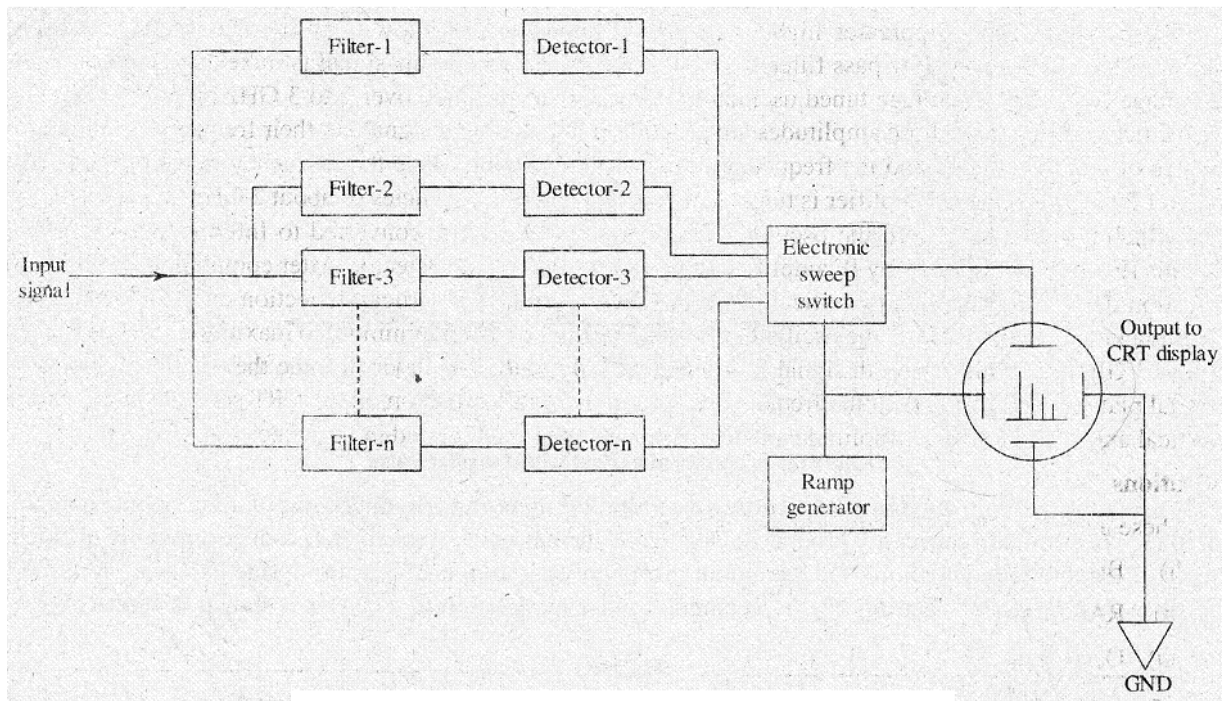

fig 7.1 Block Diagram of Filter Bank spectrum Analyzer

2. Super hetero dyne Spectrum analyzer

The modern spectrum analyzers use a narrow band super heterodyne receiver. Super heterodyne is nothing but mixing of frequencies in the super above audio range. The functional block diagram of super heterodyne spectrum analyzer or RF spectrum analyzer as shown in the Figure 7.2

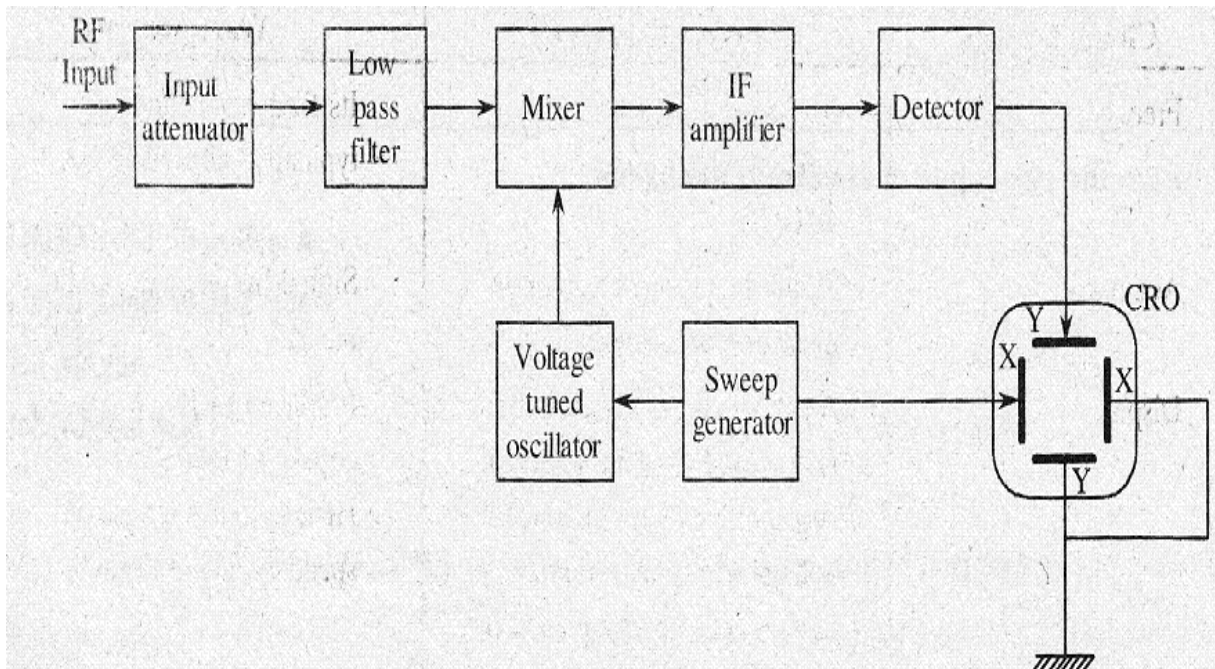

fig 7.2 Super Hertzodyne Spectrum Analyzer or RF Spectrum Analyzer

The RF input to be analyzed is applied to the input attenuator. After attenuating, the signal is fed to low pass filter.

The low pass filter suppresses high frequency components and allows low frequency components to pass through it. The output of the low pass filter is given to the mixer, where this signal is fixed with the signal coming from voltage controlled or voltage tuned oscillator. This oscillator is tuned over 2 to 3 GHz range. The output of the mixer includes two signals whose amplitudes are proportional to the input signal but their frequencies are the sum and difference of the input signal and the frequency of the local oscillator. Since the frequency range of the oscillator is tuned over 2 to 3 GHz, the IF amplifier is tuned to a narrow band of frequencies of about 2 GHz. Therefore only those signals which are separated from the oscillator frequency by 2 GHz are converted to Intermediate Frequency (IF) band. This IF signal is amplified by IF amplifier and then rectified by the detector. After completing amplification and rectification the signal is applied to vertical plates of CRO to produce a vertical deflection on the CRT screen. Thus, when the saw tooth signal sweeps, the oscillator also sweeps linearly from minimum to maximum frequency range i.e., from 2 to 3 GHz. Here the saw tooth signal is applied not only to the oscillator (to tune the oscillator) but also to the horizontal plates of the CRO to get the frequency axis or horizontal deflection on the CRT screen. On the CRT screen the vertical axis is calibrated in amplitude and the horizontal axis is calibrated in frequency.

Application:

These analyzers are widely used in the field of,

1. Bio medicals

2. RADARS
3. Oceanography

8. Explain the terms

(i) Distortion in a waveform

(ii) Distortion in a communication sign

ANS:

Distortions may be introduced in a waveform or a communication signal when they are transmitted from one point to other point through a transmission channel. The transmission channel consists of various electronic components like amplifier, heterodyning element etc. The different types of distortions that occur during transmission of an input signal (waveform or communication signal) are,

1. Linear distortions
 - (i) Amplitude distortion
 - (ii) Phase or delay distortion
2. Non-linear distortions
 - (i) Harmonic distortion
 - (ii) Inter modulation distortion.

1. Linear Distortions

(i) Amplitude Distortion

When different frequency components of the input signal are amplified or attenuated by different amounts, The output signal consists of distortions, known as amplitude distortions (i.e.) amplitude distortion occurs When the amplification or attenuation of the signal is not constant over the useful range of frequencies.

(ii) Phase or Delay Distortion

If the phase of the output signal is different from the phase of input signal then such distortion is known as phase distortion. Phase distortion leads to delay in the transmission of the signal. Hence, it is known as delay distortion. If different amounts of phase shifts occur at different frequencies of an output signal then it becomes necessary to compensate for such phase distortions. Whereas if same amount of phase shift occurs at all frequencies then such phase distortion can be ignored.

The phase distortion arises due to the presence of energy storage elements in the transmitting circuit (i.e. reactive elements such as capacitor and inductor).

2. Nonlinear Distortions

The non-linear distortions in the signal arise due to non-linear characteristics of the electronic components like amplifiers, etc. The two types of non-linear distortions are,

(i) Harmonic Distortion

The non-linear characteristics of an electronic circuit give rise to harmonics in the output signal. These harmonics produce distortions in the output signal. The distortions caused due to harmonics are known as harmonic distortions. Harmonic components occur at frequencies $2f_1$, $3f_1$, $4f_1$,..... (where. f_1 = Fundamental frequency of signal).

(ii) Inter modulation Distortion

When two signals of different frequencies (f_1 and f_2) are mixed together (i.e.....heterodyned) the resultant signal will be a sum or difference of the actual frequencies of the signal i.e. $f_1 \pm f_2$, $2f_1 \pm f_2$etc. Thus, when the signals are heterodyned additional frequency components are generated which are undesirable and which lead to distortions in the signal. The distortion caused by heterodyning of different frequency signals is known as inter modulation distortion.

9. Explain how distortion occurs during transmission of a waveform or

Ans

Distortion refers to the deviation in any parameter (like amplitude, frequency. shape) of a signal from that of an ideal signal. The non-linear characteristics of the elements of an electronic circuit give rise to harmonics in the output signal which in turn causes distortion of the output signal. The distortion caused due to harmonics is known as harmonic distortion.

The different types of harmonic distortions caused by an electronic circuit (for example, electronic amplifier are as follows,

- (i) Amplitude distortion
- (ii) Frequency distortion
- (iii) Phase distortion
- (iv) Crossover distortion
- (v) Inter modulation distortion.

(i) Amplitude Distortion

When the amplitude of the output signal is not a linear function of the amplitude and input signal is distorted under specific conditions then such type of distortion are known as amplitude distortion. Amplitude distortion occurs when the amplifier gives rise to harmonics of the fundamental frequency of the input signal.

(ii) Frequency distortion

Frequency distortion of a signal takes place when the signal is amplified by different amounts at different frequencies. This is caused mainly due to the combination of active devices and components in an amplifier.

For Example, the non uniform frequency response of RC-coupled cascade amplifier refers to frequency distortion

(iii) Phase Distortional: Is different from the phase of the input signal then such distortion is known as phase distortion.

If different amounts of phase shifts occur at different frequencies of an output signal than it becomes necessary to compensate for such phase distortions. While if same amount of phase shift occurs at all frequencies then such phase distortion cannot be ignored .the phase distortion arises due to presence of storage elements in the circuit

(iv)Crossover Distortion

The improper biasing voltages of the electromagnetic components of an amplifier (for example push-pull amplifier give rise to crossover distortion)

(v) Inter modulation Distortion

When two signals of different frequencies are mixed together (i.e., heterodyned) the resultant signal will be a sum or difference of the actual frequencies of the signals. Thus, when the signals are heterodyned, additional frequencies are generated which are undesirable and thereby leads to distortion. The distortion caused by heterodyning of frequencies is known as inter modulation distortion.

The various distortions in the signal can be analyzed using a distortion analyzer (for example, harmonic distortion analyzer).